

# TUNTURI®

## HOME CYCLE 3 SUPER AND HOME CYCLE 3 SUPER EL.

### OWNER'S MANUAL



The Tunturi Home Cycle 3 and Home Cycle 3 Super are genuine Tunturi fitness equipment intended for use at home.

The Home Cycle is an excellent fitness machine for the whole family. Easily adjusted, it is suitable for all ages, both adults and children.

For the more demanding user the Home Cycle 3 Super is equipped with a heavier flywheel, making pedalling more even than with the Home Cycle 3 version.

# ASSEMBLY AND PREPARATION FOR USE

When the cycle together with all its fittings has been removed from the packing, the cycle can be assembled, using the enclosed tools, ready for use as follows:

1. The handlebar is inserted into place and the locking knob tightened preliminarily.
2. The rear stand tube is fitted into place. Insert the bolt from the top and tighten the nut at the bottom of the tube with the spanner.
3. Remove the green threaded plugs from the righthand crank and pedal. Screw the pedal in to the crank, tightening clockwise. Remove the red threaded plugs from the left-hand crank and pedal and tighten the pedal in place. The lefthand pedal has a lefthand thread and must be tightened anticlockwise. The pedals are distinguished from each other by having R (right) and L (left) stamped on their axles. Ensure that all nuts and bolts are properly tight before using the cycle.

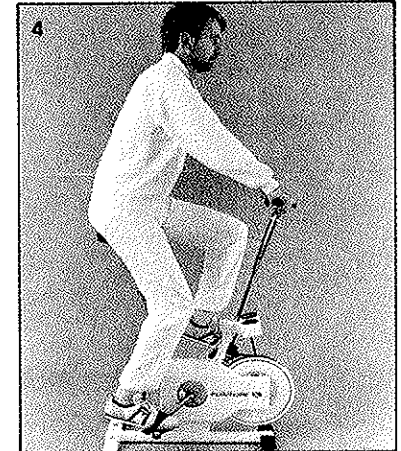
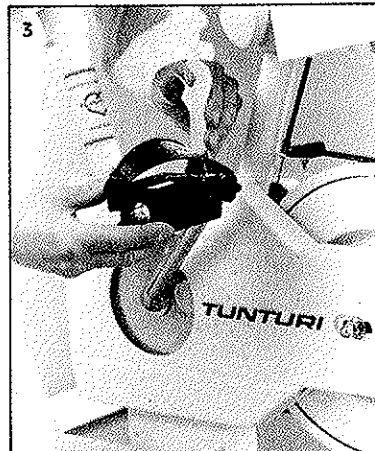
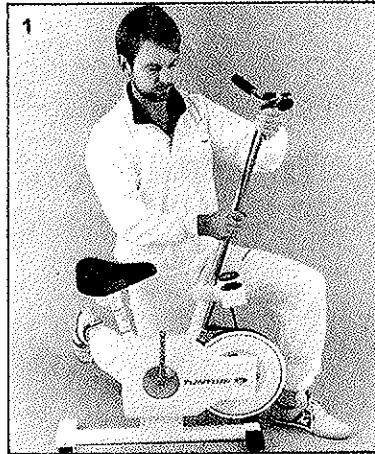

## USE

### Adjustment of saddle height

Adjust the height of the saddle so that the ball of the foot reaches the pedal with the leg almost straight and the pedal in the lowered position (Fig. 4). The angle of the saddle can be adjusted by placing different numbers of washers under the locking nuts of the saddle.

### Adjustment of handlebar

Loosen the triangular locking nut on the handlebars and adjust the distance between the saddle and the handlebar so that the person using the cycle can pedal with his arms almost straight and so that the pedalling position feels comfortable. Do not raise the handlebar or the saddle above the "Min" mark on the handlebar and saddle supports.

### Adjustment of resistance

Pedalling resistance can be adjusted by means of the regulating lever on the handlebar.

### Pedalling

Begin pedalling at a low resistance. After a few minutes to warm up, the resistance can gradually be increased.

### Timer

The timer can be used to keep a record of the time spent pedalling. Set the clock to the appropriate time, eg. 15 minutes, by turning in a clockwise direction. When the bell rings, then the exercise time is up.

## SERVICE AND STORAGE TECHNICAL SPECIFICATIONS

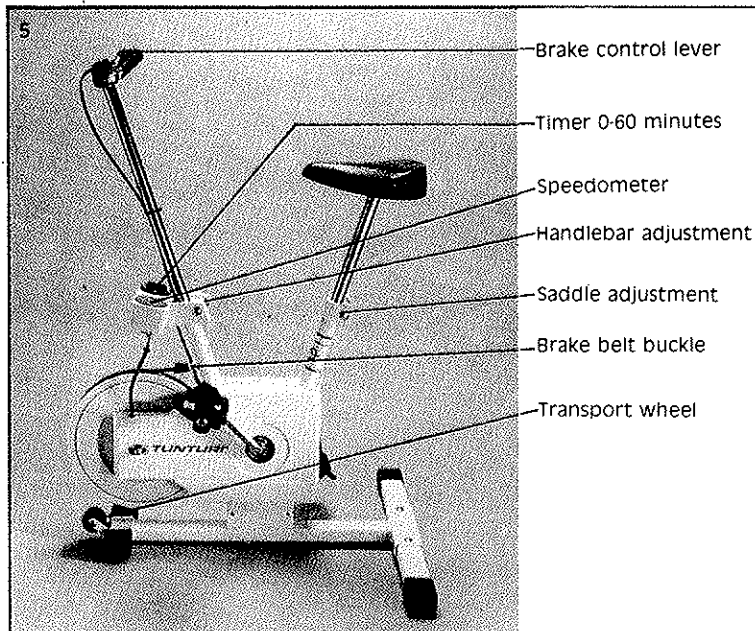

### Storage

To avoid damage or disturbance to the Tunturi Home Cycle, it is best to keep it in a dry, dust-free place at an even temperature. Use in damp conditions is not recommended as this may cause the flywheel to rust and result in inaccuracy in operation.

### Gymnasium use

If the Home Cycle is used professionally or in gymnasiums, then the service described below should be carried out more frequently, the intervals depending on the degree of use.

### Service

The Tunturi Home Cycle is robust and is made to withstand continuous use. To keep it in good condition and at a high state of efficiency, it is important to perform certain simple service and adjustment operations at regular intervals as follows:

The tension of the brake cable should be adjusted when necessary. This is done by undoing the buckle on top of the flywheel and pulling the brake cable tighter. Correctly adjusted, the flywheel should rotate freely when the adjustment lever on the handlebar is in the 0-position.

Oil the chains with a few drops of oil twice a year. Excess oil should be wiped off. The righthand chain guard should be removed for lubrication. Lubrication is best done with an aerosol spray.

If the chains give rise to noise, they are either too tight or too loose. Adjust by loosening the locking nuts on the flywheel axle and moving the flywheel forwards or backwards. After tightening the nuts ensure that the chain runs true. The threads on the locking nuts of the saddle and handlebars should be greased about twice a year. Water-soluble detergents may be used for cleaning the plastic guards. Solvents must not be used.

## CONSTRUCTION AND TECHNICAL SPECIFICATIONS

- length 73 cm
- width 51 cm
- height 77-107 cm
- weight 22 kg, Super 26 kg
- flywheel weight 8 kg, Super 12 kg
- adjustment range of handlebars 30 cm
- adjustment range of saddle 40 cm
- strong steel tube frame
- durable cable brake, infinitely variable adjustment of resistance
- white shock resistant paint
- speedometer and timer standard equipment
- safe construction

# SPARE PARTS

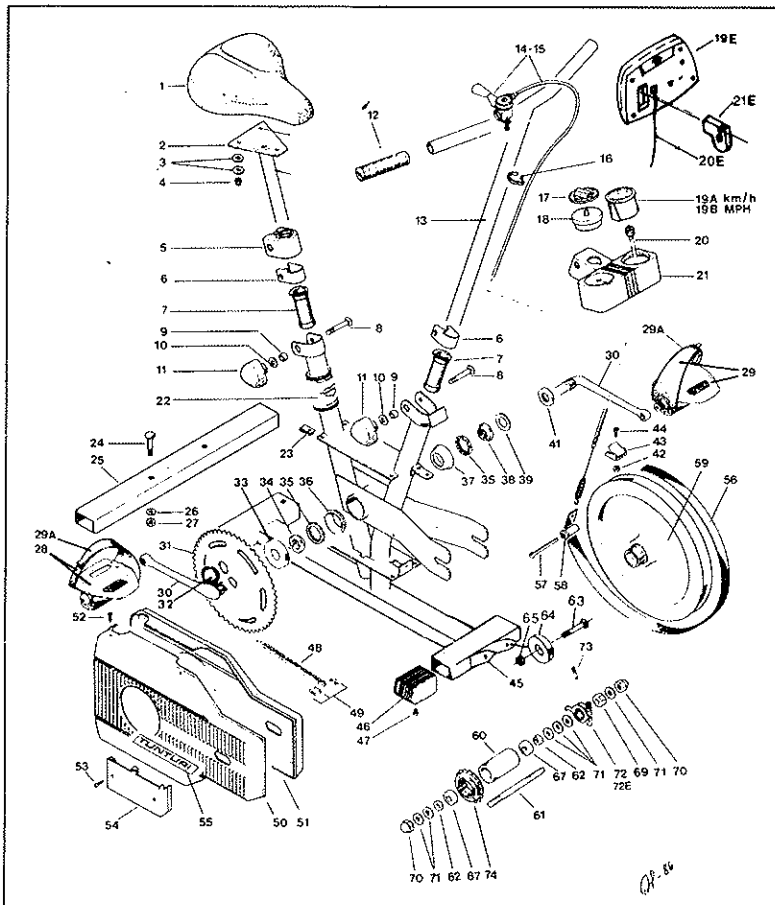

Pict. nr.	Part nr.	Fig. nr.	Part nr.
1	153.102.81	36	522.100.86
2	153.154.86	37	653.101.86
3	653.135.86	38	522.103.86
4	653.113.86	39	652.101.86
5	173.112.83	41	522.105.86
6	513.204.82	42	653.115.86
7	533.122.86	43	503.117.85
8	653.172.86	44	653.180.86
9	523.104.86	45	103.116.86
10	653.132.86	46	533.117.83
11	653.104.86	47	653.181.86
12	212.104.80	48-49	252.037.10
13	203.102.86	49	252.000.10
14-15	223.131.86	50	143.119.83
16	223.118.82	51	143.120.83
17	233.144.86	52	653.182.86
18	233.128.86	53	653.183.86
19A	233.145.86 km/h	54	433.101.83
19B	233.145.86.1 MPH	55	423.115.86
19E	233.184.88	56	443.111.84
20	223.130.86	57	663.105.86
20E	403.103.88	58	533.106.78
21	173.109.83	59-65	303.110.86*
21E	503.125.88	59	303.109.86*
22	423.163.86	60	333.110.86
23	651.900.86	61	343.114.86
24	653.179.86	62	651.106.86
25	103.115.83	63	60.08.040.00
26	653.136.86	64	533.168.88
27	655.114.86	65	61.0810
28-29	363.132.84	67	523.110.86
28	363.133.84	69	651.107.86
29	363.134.84	70	651.105.86
29A	363.131.84	71	652.130.86
30	352.100.86	72	233.146.86
31	263.103.86	72E	233.185.88
34	522.102.86	74	263.100.68
35	522.104.86		

\* E For electronic meter components

## WHAT TO DO IF...

FAULT	POSSIBLE CAUSE	CORRECTIVE MEASURE
Handlebar wobble/saddle loose.	Locking nuts loose.	Undo nut and grease threads. Tighten by hand.
Brake not working	Brake cable too loose.	Undo brake buckle and tighten.
Pedal wobbles.	Pedal axle loose.	Tighten pedal on to crank with spanner. See assembly/3.
Undue noise from chains.	Chains dry. Chains too tight. Chains not running true.	Remove righthand chain guard and oil chains. Loosen locking nuts on flywheel and move flywheel back slightly. Remove righthand chain guard. Loosen locking nuts on flywheel axle and adjust the angle of the chains.
Chains catching on guards.	Chains loose or too close to guards.	Loosen locking nuts on flywheel axle and move flywheel forwards slightly.

Designed by Tunturi Oy  
SF-20760 Piispanristi FINLAND  
Tel: +358-21-42 42 00 Telex: 62 617  
Telefax: +358-21-42 33 88

Tunturi Inc.  
P.O. Box 2470, REDMOND, WA 98073-2470, U.S.A.  
Tel. (206) 881-8156  
Fax (206) 881-7178